



THE LEADER IN

## INNOVATION

A true pioneer in our industry, most metal enclosed high voltage cable couplers in service today are based on designs originated by the founder of TJB. Since our inception in 1970, we have continually introduced innovative design improvements to cable couplers that have set the standard for our industry world-wide. Remaining an industry leader is our goal. Quickly responding to the ever-changing needs of our customers in the mining and tunneling industries is the way we have been able to achieve that goal. Our research and development efforts have resulted in a number of dynamic design advantages unique to TJB couplers. This investment has enabled us to introduce innovations that reduce down-time, and dramatically cut the costs related to installation and service of cable systems.

THE LEADER IN

## QUALITY

Our customers have learned to depend upon the uncompromising quality of our products and the value that this quality represents. Our couplers must function for long periods in the most hostile environments. With this in mind we have implemented continual quality testing and controls throughout our production processes.

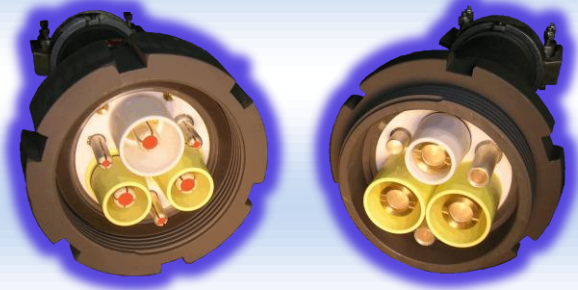

THE LEADER IN

## SERVICE

When you need it...and you need it now, TJB is your answer. We offer the widest variety of couplers in the industry and with our extensive inventory and automated fulfillment systems we are able to provide same-day shipping of most of our products.

At TJB, the needs of our customers are our number one priority. To meet those needs, our highly trained and experienced design and production team is at your disposal to supply any custom configuration that your application might require.

Our continual innovation, consistent quality and dependability translate into real value that our customers have grown to expect.

TJB primarily services the mining and tunneling industries with solutions to their cable coupler challenges. Our cable couplers provide a flexible, convenient, dependable means for extending portable power cable from power sources to mining and earth moving equipment.

# TJB HIGH VOLTAGE COUPLERS

# TJB CLOSURE TYPES

TJB SUPPLIES THREE METHODS OF MECHANICAL CONNECTION FOR HIGH-VOLTAGE CABLE COUPLERS. THE OLDEST METHOD IS THE 8 PITCH THREAD. THIS CLOSURE INCORPORATES AXI-NUT ACTION AND BLUNT-START, RELIEVED THREAD DESIGN, ALL OF WHICH CONTRIBUTE TO EASIER OPERATION AND LONGER LIFE.

THE FLOATING AXI-NUT ALLOWS THE PLUG TO BE INSERTED INTO THE SOCKET, THE NUT MORE EASILY STARTED, AND SECURES THE COUPLER BY COMPRESSING THE O-RING SEAL. THE "BLUNT START" AND "RELIEVED-THREAD" FEATURES AID IN PREVENTING "FIRST-THREAD ROLLOVER," COMMON IN COUPLERS NOT SUPPLIED WITH THESE FEATURES, WHICH MAY RESULT IN JAMMING OF THE NUT.

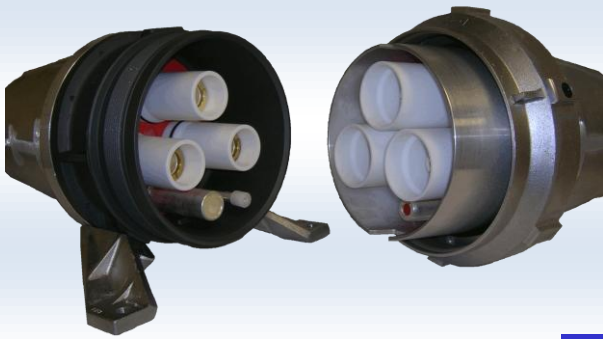

*FAST COUPLING*

**8 PITCH**

**COUPLERS**



*FASTER COUPLING*

**4 PITCH**

**COUPLERS**

A SECOND TYPE OF CLOSURE SUPPLIED INCORPORATES A 4-PITCH ACME, DOUBLE START THREAD, AGAIN WITH "BLUNT-START" AND "RELIEVED-THREAD" FEATURES.

THIS DESIGN ALSO INCLUDES THE SAME AXI-NUT ACTION DESCRIBED ABOVE, MAKING THE COUPLING ACTION MORE RAPID THAN OTHER BRANDS.

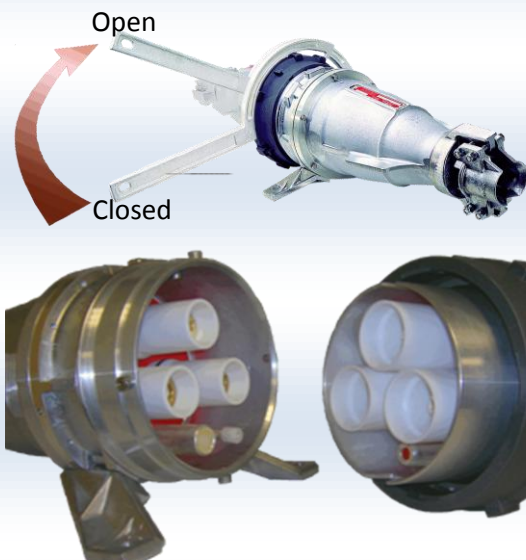

THE THIRD AND BEST TYPE OF CLOSURE UTILIZES A PIN-AND-SLOT DESIGN WHICH REQUIRES ONLY A 90 DEGREE ROTATION OF THE NUT TO LOCK, CLOSE AND COMPRESS THE "O" RING SEAL. DETENTS PREVENT UNINTENTIONAL OPENING DUE TO VIBRATION.

THIS DESIGN LENDS ITSELF TO EASY CONVERSION OF EXISTING 8 OR 4 PITCH THREADED COUPLERS TO THE NO-THREAD CONCEPT. SUCH A CONVERSION REQUIRES A MINIMUM OF TIME (LESS THAN AN HOUR FOR A SET OF COUPLERS) AND IS ECONOMICAL IN CONVERSION COST. OPERATING TIME (OPENING OR CLOSING) IS MEASURED IN SECONDS, RATHER THAN THE 5 TO 15 MINUTES THAT MAY BE REQUIRED WITH OTHER TYPES OF CLOSURES.

*FASTEST COUPLING*

**NO THREAD**

**COUPLERS**

# COUPLER

## SELECTION GUIDE

SAMPLE CATALOG NUMBER:

**S F L - N T ? ?**

### HOUSING TYPE

P = Plug (Rotating Nut/Collar)  
S = Socket (External Thread)

### MOUNTING

L = Line/Cable Mounted  
G = Gear/Box Mounted

### CLOSURE TYPE

F = Fine Thread (8 Pitch)  
C = Coarse Thread (4 Pitch)  
N = No Thread (1/4 Turn)

### CONTACT GENDER

M = Male  
F = Female

### INSULATOR

H = Hard Rubber  
T = PTFE

Standard couplers include: one ground check, dust cover, threaded phase contacts, ground contact and shield terminating materials where applicable.

### OPTIONAL FEATURES

- 1 = Non Threaded Contacts
- 1A = Setscrew Phase and Ground Contact
- 1B = 1-1/2 Backend on Phase Contacts for 500 MCM Cable – Solder
- 2A = 8KV Interlocking Cover
- 2B = 15KV Interlocking Cover with EP Rubber Cups
- 2C = 15KV Interlocking Cover with PTFE Cups
- 3 = Kirklock Plain Push On Cover
- 3A = Kirklock Heavy Duty O-Ring Sealed Screw on Cover
- 3B = Padlock Device
- 4 = 2 Ground Checks
- 4A = 3 Ground Checks
- 4B = 4 Ground Checks
- 5 = Large Bell 3.01" Cable and Larger
- 5A = Large Bell 3.00" Cable and Smaller (For Phase Crossing)
- 5B = Large Bell 3.01" and Larger with Extension
- 5C = Large Bell 3.00" and Smaller with Extension
- 5D = Gear Flange Extension
- 5E = Gear Flange Extension with One Piece Foot
- 5F = Plug Flange on Gear Mounted Socket
- 6 = 4 Hole Foot
- 6A = Footless
- 8 = Pipe Plugs in End Bell
- 8A = Fibre Optic Cable Exit Gland
- 8B = Split End Casting
- 9 = Hard Anodize all Surfaces for Additional Corrosion Protection
- 9A = Hard Anodize all Surfaces and Epoxy Paint
- 9B = Coated with Everslick 1201 (Resistant to Sulfuric Acid)

**25 KV AVAILABLE**  
**Refer to Factory**

# MOUNTING & CLEARANCE

## DIMENSIONS - 15 KV COUPLERS

### GEAR MOUNTED SOCKET

6 HOLES EQUALLY SPACED ON 8 5/8" B.C. FOR 1/4" BOLTS

7 1/4" DIA. CUTOUT IN SWGR. FACE  
2 HOLES FOR 3/8" BOLTS

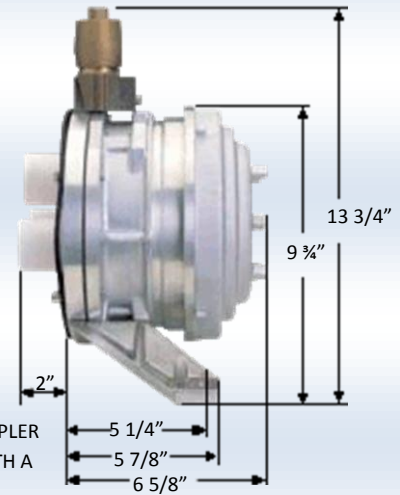
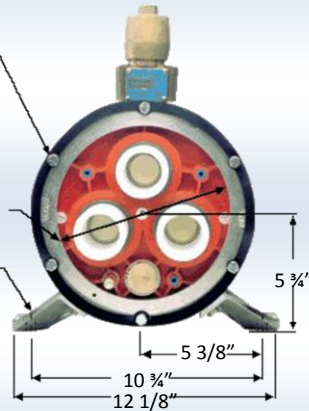

IF YOUR COUPLER IS FITTED WITH A 3-P LOCK, 6 HOLES WILL BE ON 8 5/8" B.C. STARTING ON THE VERTICAL CENTER LINE

### GEAR MOUNTED PLUG

6 HOLES EQUALLY SPACED ON 7 7/8" DIA. BOLT CIRCLE FOR 1/4" BOLTS

18 1/2" WRENCH RADIUS

7 1/4" DIA. CUTOUT IN SWITCHGEAR FACE

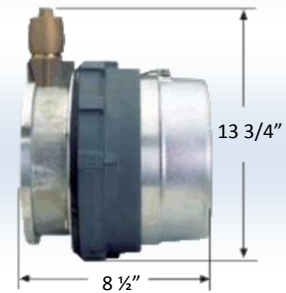
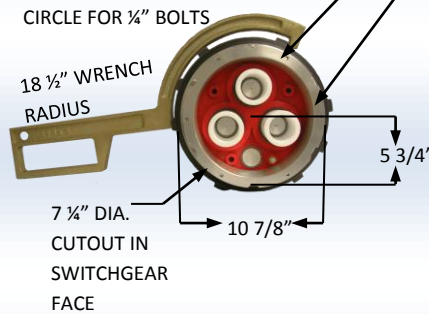

### ASSEMBLED LINE MOUNT COUPLER

STD-3" O.D. CABLE  
5 & 5A-4 1/4" O.D. CABLE  
5B & 5C-4 1/4" O.D. CABLE

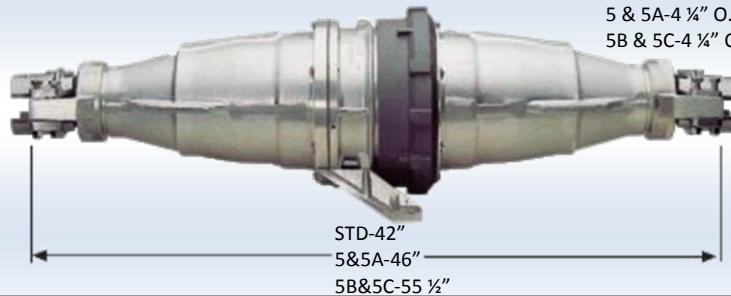

## COUPLER TIPS

- Occasionally, a nut will freeze and be difficult to turn. If it is a two part nut (non TJB), remove the six screws holding the back ring, then gently tap the nut all around its circumference. Because of the designed looseness of the thread, there should be enough movement to loosen the nut. If a TJB plug, slightly loosening the 6 screws and wiggling the coupler should do it. TJB's stainless steel thread should eliminate this problem.
- Couplers serve as a visible disconnect, but are not meant to be opened either under load or with voltage applied. Make sure circuit breaker is open and phase conductors grounded. Do not depend on ground check circuit to open breaker.
- When couplers have been separated after being energized, some residual voltage may be left on the phase leads. If the phase contacts must be touched, use an earth-attached ground to discharge all contacts prior to touching them.
- Good housekeeping in the form of clean insulators is mandatory at 15KV levels and desirable at all voltages. Periodic cleaning should be done on both male and female insulators. The use of PTFE insulators eliminates most insulator problems and makes cleaning a very quick and simple process.

# INNOVATIVE FEATURES

TO MEET THE CONTINUING NEED FOR INCREASING THE PRODUCTIVITY OF MINING OPERATIONS, REDUCING DOWNTIME AND SIMPLIFYING INSTALLATION AND SERVICING OF CABLE SYSTEMS, TJB COUPLERS PROVIDE A NUMBER OF IMPORTANT DESIGN ADVANTAGES. EACH CONTRIBUTES TO EASIER INSTALLATION, QUICKER COUPLING OR UNCOUPLING, GREATER ELECTRICAL INTEGRITY AND GREATER FREEDOM FROM PROBLEMS INHERENT IN THE USAGE OF HIGH-VOLTAGE PORTABLE CABLE SYSTEMS UNDER THE EXTREME ADVERSE CONDITIONS OFTEN ENCOUNTERED IN MINING. COLLECTIVELY THEY PROVIDE LOWER INSTALLATION AND OPERATING COSTS, EASIER AND FASTER SERVICING, AND GREATER OVERALL ELECTRICAL SYSTEM RELIABILITY.

**TJB pioneered the use of a PTFE insulator in 1994. Your best choice for downtime reduction.**

**FEMALE COPPER CONTACTS**  
- Never inferior brass

**MALE SPLIT TYPE COPPER CONTACTS**  
- with silicone button for increased contact pressure when loads are high

**SILVER PLATED GROUND CHECK CONTACTS**

**ANGLED "SLEDFOOT" FACILITATES MOVING COUPLERS**  
(at least in one direction)

**3 END BELL SIZES** ▶ *eases tight fits*

**WHERE LARGER, STIFFER CABLES ARE INVOLVED, TJB OFFERS A CHOICE OF LONGER, LARGER-ENTRANCE END-BELLS. TWO SIZES ARE AVAILABLE THAT CAN ACCOMMODATE CABLE SIZES THROUGH 4 1/4" O.D., WITH CLAMPS TO FIT CABLES 1 1/4" - 4 1/4" O.D. WHERE END-BELL EXTENSION IS REQUIRED FOR PHASING CONDUCTORS OR APPLY FOOT TO CABLE MOUNTED PLUG. A FLANGE INSERT IS AVAILABLE.**

**PTFE OR HARD EP INSULATORS** ▶ *to meet industry needs*

**TJB COUPLERS OFFER A CHOICE OF A SEMI-RIGID EP (ETHYLENE PROPYLENE) MOLDED INSULATOR OR A PTFE INSULATOR INTRODUCED BY TJB IN 1994 WHICH HAS RAPIDLY BECOME THE INDUSTRY STANDARD.**

**AUTOLIGN** ▶ *for quick alignment*

**TJB PLUGS AND SOCKETS ALIGN MORE EASILY EVEN WHERE VISIBILITY IS POOR. A FULL-LENGTH SLOT IN THE PLUG BODY AND CORRESPONDING PIN IN THE SOCKET BODY GUIDE THE HOUSINGS AND CONTACTS INTO PROPER ALIGNMENT.**

**WATERTIGHT GASKETING KEEPS OUT MOISTURE**

**HOUSINGS GROUNDED INTERNALLY TO CABLE GROUND WIRE**

**STAINLESS STEEL THREAD** ▶ *reduces galling*

**GALLING OR "LOCK-UP" OF ALUMINUM TO ALUMINUM THREADS WHICH CAN OCCUR AFTER SURFACE FILMS, DRY LUBRICANT OR ANODIZING WEAR OFF, IS PREVENTED BY THIS ORIGINAL TJB DESIGN FEATURE. A STAINLESS STEEL INSERT IN THE TJB LOCKING NUT PRODUCES A CONNECTION WHICH IS NON-CORROSIVE AND LESS SUBJECT TO DIRT ACCUMULATION, ELIMINATING PROBLEMS FROM ALUMINUM-TO-ALUMINUM CONTACT.**

**"SPIN-ON" AXI-NUT** ▶ *speeds coupling*

**TJB DESIGN ENABLES EASIER THREAD STARTING BY FLOATING THE NUT. THIS ALLOWS THE MATING COUPLER TO BE PARTIALLY INSERTED WITH THE THREADS ALIGNED, BY SLIDING THE NUT, NOT THE ENTIRE COUPLER. AXI-NUT IS FACTORY ASSEMBLED TO PLUG BODY WITH SELF-LUBRICATING NYLON BALL BEARINGS, PROVIDING A ROLLING RATHER THAN SLIDING CONTACT WHICH RESULTS IN EASIER OPERATION.**

**8 TIMES THE CREEPAGE PATH TO GROUND**

**CREEPAGE PATH BETWEEN GROUND AND GROUND CHECK WITH MOST COUPLERS IS AS SMALL AS 1/8" - A DISTANCE EASILY BRIDGED IN DAMP, DIRTY LOCATIONS, RESULTING IN SHORT CIRCUITING THE DESIRED CONTINUITY CHECK THROUGH THE CABLE. TJB INSULATORS HAVE 8 TIMES THE CREEPAGE PATH FROM GROUND-CHECK TO GROUND OF OTHER COUPLERS.**

**CUTAWAY VIEW OF CABLE-MOUNTED PLUG WITH MALE CONTACTS, ENGAGED WITH SWITCH-GEAR MOUNTED SOCKET WITH FEMALE CONTACTS.**

**CABLE CLAMP RELIEVES STRAIN ON CONDUCTOR TERMINATIONS**

**HIGH STRENGTH LIGHTWEIGHT ALUMINUM HOUSING PROTECTS CONTACTS**

**POSITIVE HOUSING ENGAGEMENT -1 of 3 types**

**TJB**      **OTHER**

# MSHA

## CERTIFIED COUPLERS

### MEET MSHA AND IEEE TEST STANDARDS

The concept of replaceable cables and cable couplers on high-voltage equipment has been recognized as practical for many years. Now, with increased emphasis being placed on limiting the number of temporary splices made in trailing cables, the use of permissible couplers and replaceable medium voltage cables is gaining in increasing acceptance.

TJB Trailing Cable Couplers are designed to expedite cable changes and minimize downtime. Heavy duty aluminum housings enclose PTFE or polyester insulators which support pin-and-socket type contacts. Contacts attach to conductors by set screws, or by soldering. TJB Couplers carry MSHA Certification and are constructed in accordance with Pennsylvania requirements.

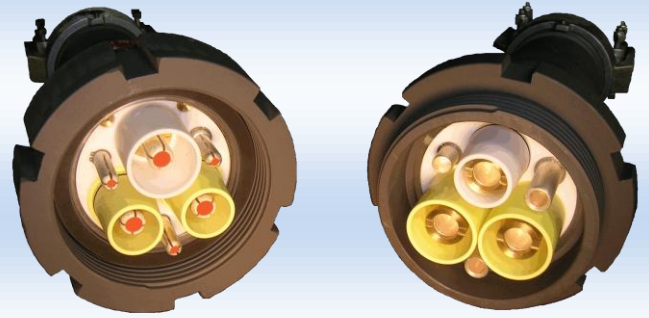

**220 -5000 VOLTS**

**700 AMPERES**

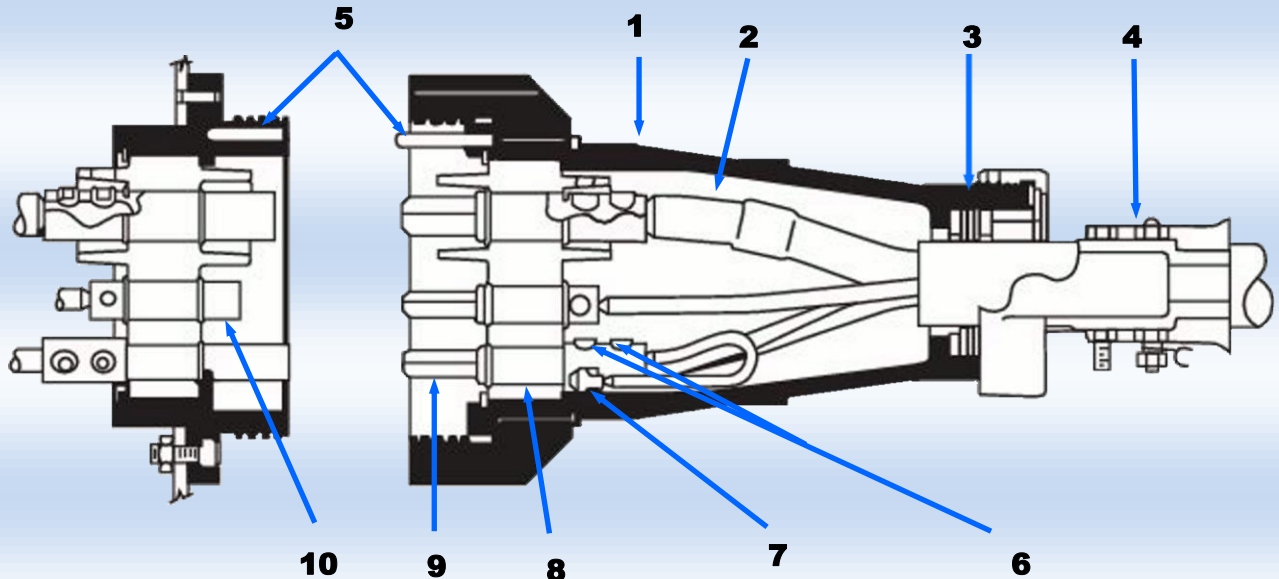

#### MECHANICAL

1. **HEAVY WALL SECTIONS** surpass M.S.H.A. requirements – provide more than adequate strength for rugged mine usage.

2. **AMPLE SPACE** for phase conductors in end bells. Accepts up to 500 mcm 5KV insulated cables, through 3.31” O.D. jacket.

3. **EXPLOSION-PROOF SEAL** provided by Neoprene packing rings.

4. **HEAVY-DUTY, 4 BOLT-CLAMP** supports cables, prevents loosening of entrance seal due to cable movement.

5. **VARIABLE ALIGNMENT PIN POSITIONS** permit keying for differing breaker settings to prevent misconnection. Available with Polyester insulators only.

#### ELECTRICAL

6. **COUPLERS** up through 350 mcm, set screw attached. 500 mcm solder attached.

7. **END BELL GROUNDED** to cable ground wires. Also available ungrounded for special circuits.

8. **PTFE OR POLYESTER INSULATORS** will not support combustion.

9. **PIN-AND-SOCKET TYPE CONTACTS** self-cleaning upon engagement. All contacts EC grade copper and silver plated. Includes 3 phase, 2 ground and 1 ground check contact.

10. **CONTACTS ARRANGED** so ground-check circuit opens first, phase circuits next, ground circuits last. Phase contacts open while housing is still permissible.

# DESIGN FEATURES

# MOUNTING & CLEARANCE

## DIMENSIONS 220 – 5000V COUPLERS

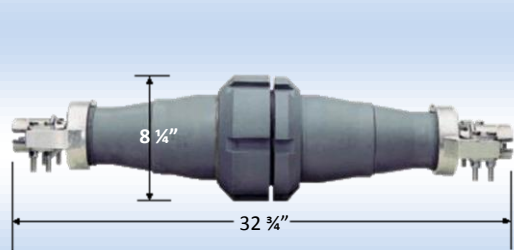

6 HOLES EQUALLY SPACED ON 7 1/4" B.C. FOR 3/8-16 MTG. BOLTS

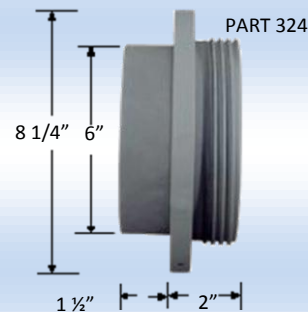
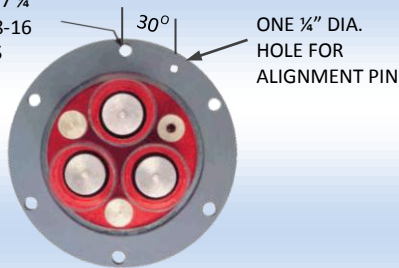

WELDING FLANGE



PLUG HOUSING CAN BE REMOVED FROM WELDING FLANGE FOR FLANGE INSTALLATION OR NUT REPLACEMENT

PLUG NUT

FLANGE MOUNTED PLUG

CABLE SIDE VIEW

6 HOLES EQUALLY SPACED ON 6 5/8" B.C. FOR 3/8-16 MTG. BOLTS

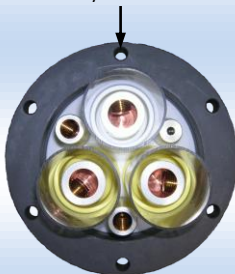

FLANGE MOUNTED SOCKETS

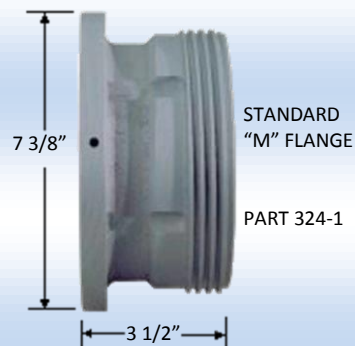

		POLYESTER				PTFE
MSHA CERTIFICATION		X/P-1944-3				18-XPA060003-0
PA APPROVAL		BFE 573-76				BFE 573-76
MAXIMUM VOLTAGE		1000V	2400V	4160V	4160V	
MAXIMUM CONDUCTOR SIZE		350 MCM	500 MCM	350 MCM	500 MCM	350 MCM
COUPLER CONFIGURATION	CAT. NO.	CAT. NO.	CAT. NO.	CAT. NO.	CAT. NO.	CAT. NO.
Cable Mounted Socket-Female Contacts	113-1-4	116-1	313-1-4	316-1	513-1-4	SFLXP5
Cable Mounted Plug-Male Contacts	H143-1Y-4	H146-1Y	H343-1Y-4	H346-1Y	H543-1Y-4	PMLXP5
Flange Mounted Socket-Female Contacts	M153-1-4	M156-1	M353-1-4	M356-1	M553-1-4	SFGXP5
Flange Mounted Plug-Male Contacts	H183-1Y-4	H186-1Y	H383-1Y-4	H386-1Y	H583-1Y-4	PMGXP5
Cable Mounted Socket-Male Contacts	133-1Y-4	136-1Y	333-1Y-4	336-1Y	533-1Y-4	SMLXP5
Cable Mounted Plug-Female Contacts	H123-1-4	H126-1	H323-1-4	H326-1	H523-1-4	PFLXP5
Flange Mounted Socket-Male Contacts	M173-1Y-4	M176-1Y	M373-1Y-4	M376-1Y	M573-1Y-4	SMGXP5
Flange Mounted Plug-Female Contacts	H163-1-4	H166-1	H363-1-4	H366-1	H563-1-4	PFGXP5

### OPTIONAL FEATURES

SUFFIX	DESCRIPTION
L	Large entrance end bell for cable 3.01" and larger
T	Large entrance end bell for cable 3.00" and smaller
6	Set screw phase contacts for couplers listed under 500 MCM up to 350 MCM only. 500 MCM solder attached
PREFIX	DESCRIPTION
M*	7 3/8" Diameter Socket Flange (Standard)

### DATA REQUESTED ON ORDER:

1. Complete Catalog Number
2. Line Conductor Size, Stranding
3. Number and Size Ground Wires
4. Number and Size Ground Check Wires
5. Diameter Over Cable Jacket

### FLANGE MOUNTS

Flange-mount SOCKETS will be shipped using No. 324-1 flange. Gear-mount PLUGS include welding flange No. 324-2B.

### WELDING FLANGES FOR SOCKETS

For No. 324 flange, specify No. 324-2A  
For No. 324-1 flange, specify No. 324-2

\*If prefix "M" is not specified, an 8-1/4" diameter socket flange is provided. Available with polyester insulator only.

# LVNT COUPLERS

480 VOLT – 5KV 700 AMPS

## VIEW OF THE 480V FRONT ENDS

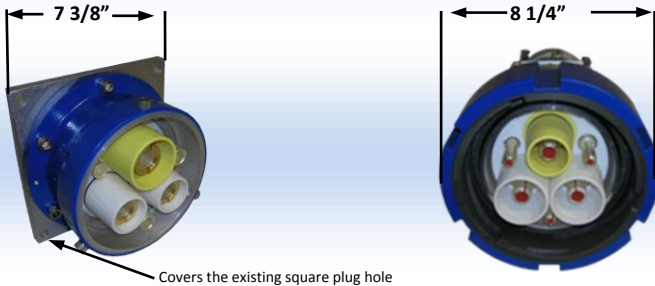

## VIEW OF THE 1KV FRONT ENDS

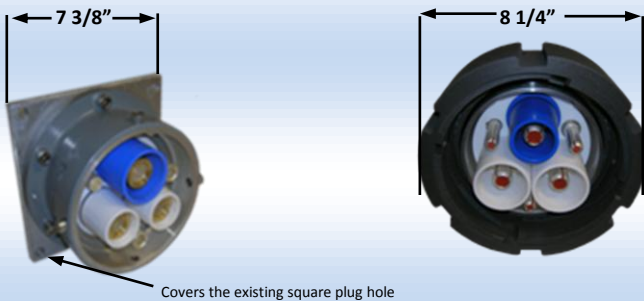

## VIEW OF THE 3KV FRONT ENDS

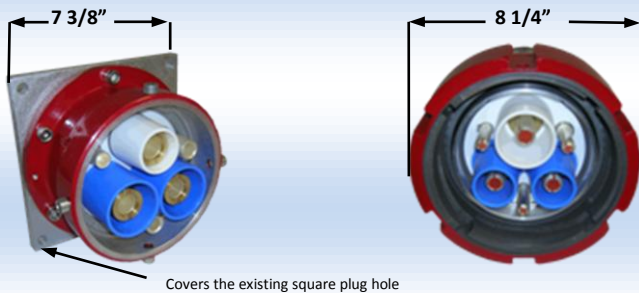

## VIEW OF THE 5KV FRONT ENDS

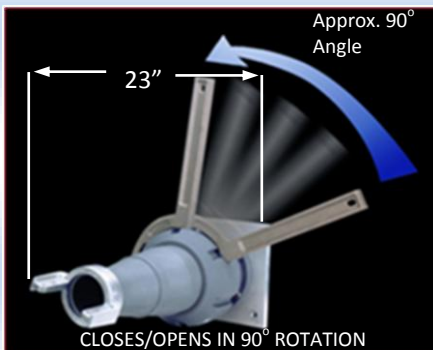
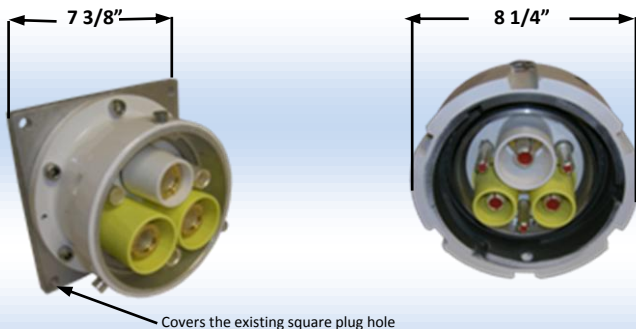

## SQUARE PLUGS BURNING UP?

## TJB HAS THE SOLUTION!!

Our line of quarter turn couplers has been tested at 800 amps continuous duty and are **GUARANTEED** to solve your contact burning problems. If you ever have contact burning problems with one of our new couplers we will replace it with a new one. That is how sure we are that TJB couplers are capable of handling your loads.

As our salespeople traveled around the coalfields they always heard the same complaints about the square plugs-broken housings and burned contacts.

Having forty years of coupler designing experience behind us, we have developed a replacement that will bolt directly into your existing power center panel and eliminate your square plug headaches once and for all.

Similar in design to our 15KV No-Thread (Quarter Turn), this smaller coupler utilizes the same PTFE tubes that have so dramatically reduced coupler failures in our high voltage line.

Please order using the following numbers:

480 VOLTS 700 AMP				
1KV 700 AMP				
3KV 700 AMP				
5KV 700 AMP				
SFG48	SFG1	SFG3	SFG5	Socket, Female Contacts, Gear Mounted
PML48	PML1	PML3	PML5	Plug, Male Contacts, Line (Cable) Mounted
SFL48	SFL1	SFL3	SFL5	Socket, Female Contacts, Line (Cable) Mounted

Give them a try; your contact problems will be gone for good. We Guarantee it.

# MLVNT COUPLERS

1KV 500 AMPS

Once again, complaints in the field regarding the durability of square plugs have prompted our design team to provide a solution. Our new line of quarter turn couplers will bolt right into your existing power center panel and eliminate your square coupler headaches once and for all. Similar in design to our 1 -5 KV, 700A coupler, this smaller 1 KV, 500A version utilizes No-Thread (1/4 turn) closure and a PTFE insulator.

Design features include setscrew style contacts, four slots, 90° apart in the insulator which allows up to four mounting positions (to prevent inter-connect-ability between circuits), mounting feet on the socket, and field proven cable seal/hose clamp cable entrance.

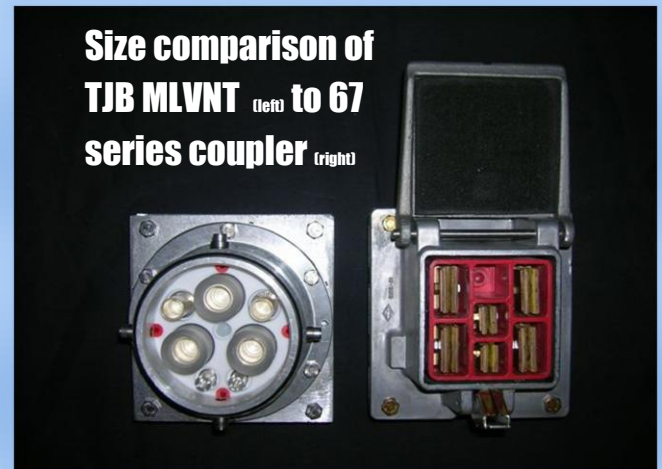
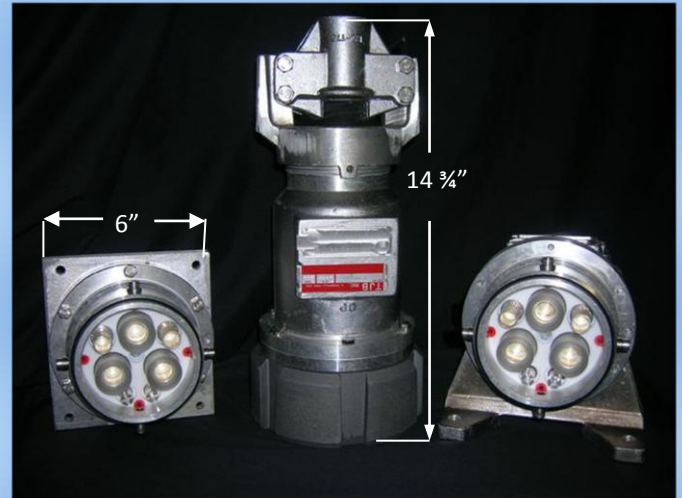

Please order using the following numbers:

<b>MPML1</b>	<b>Plug, Male Contacts, Line (Cable) Mounted</b>
<b>MSFL1</b>	<b>Socket, Female Contacts, Line (Cable) Mounted</b>
<b>MSFG1</b>	<b>Socket, Female Contacts, Gear (Box) Mounted</b>
<b>MPMG1</b>	<b>Plug, Male Contacts, Gear (Box) Mounted</b>